

# VECYS®

**WARNING:**

- Please read and understand this entire manual before attempting to operate or use the product. This will ensure you receive the most enjoyable and trouble-free operation of your new water cooler.
- After receiving the machine, please leave it alone for over 24 hours on a flat surface and then start up the machine.

## WELCOME TO GET SUPPORT FROM US

# VECYS®

## WATER COOLER

# INSTRUCTION MANUAL

**IMPORTANT:** READ CAREFULLY, RETAIN FOR FUTURE REFERENCE. MANUAL MUST BE READ BEFORE OPERATING!

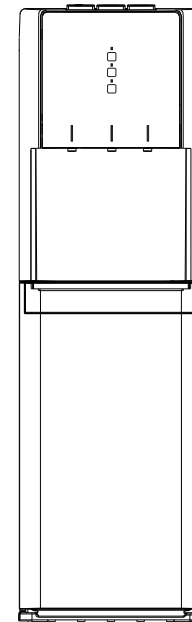

Model: FY605

CE CB  Intertek

## PARTS NAME

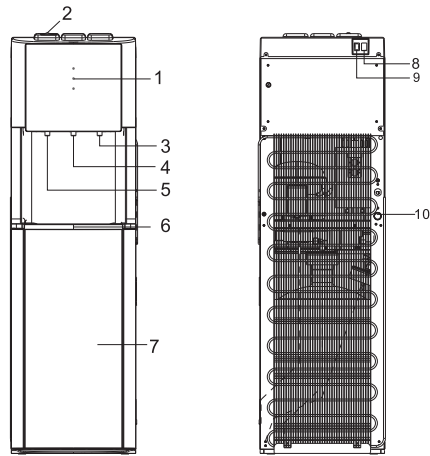

NO.	NAME	NO.	NAME
1	Pilot Lamp	6	Drip Tray
2	Safety Lock	7	Lower Door
3	Cold Water Faucet	8	Heating Switch
4	Normal Water Faucet	9	Cooling Switch
5	Hot Water Faucet	10	Electric Power Cord

## TECHNICAL PARAMETERS

Model	FY605
Water source	Tap water
Working pressure	0.1MPa-0.4MPa
Pure water flow	≥0.5L/Min
Total pure water	2000L
Electric shock type	I
Rated voltage/frequency	115V-60Hz
Heating power	500W
Cooling power	85W
Heating capacity	5L/h, ≥90℃
Cooling capacity	2L/h, ≤10℃
Ambient temp	ST

All this product's parameters relating to its performance, are test results under the standard test condition, will change with the different using conditions in the process of actual use.

## CIRCUIT ILLUSTRATION

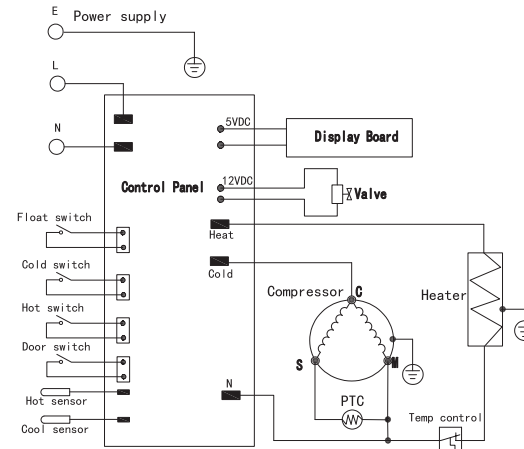

## WATER TREATMENT FLOW CHART

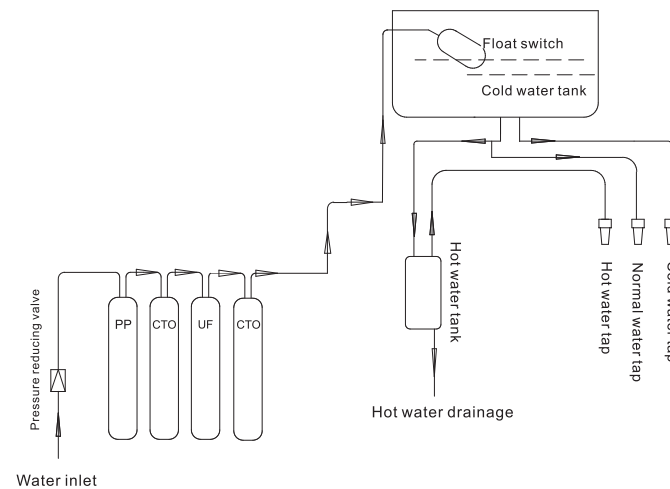

## FILTER FUNCTION INTRODUCTION

Filter name	Function	Material	Specification	Quantity
PP filter	Effectively remove the impurities which are bigger than 5 $\mu$ , such as suspended solids, sediment, red worm, rust and other solid impurities.	PP	5 $\mu$	1pc
CTO filter	Remove large particles water impurities, high absorption residual chlorine in water and organic matter, removal water color, odor, etc.	Active carbon	6-40 $\mu$	2pc
UF	Effectively intercept the water tiny suspended solids, colloid, particles, bacteria, etc., the filtered water can be directly drinkable.	PP	0.01 $\mu$ -0.1 $\mu$	1pc

## MAIN COMPONENTS LIFE

In order to ensure that all parts give full play to their respective role, and confirm that the water quality reach the standard, the user should replace the components periodically, the user can refer to the following estimated replacement cycle (20L water per day).

Part Name	Recommend replacing period (month)
PP	6~12
CTO	6~12
UF	12~18

The filter life will be influenced by various aspects, such as raw water temperature, raw water pressure, raw water quality, water usage and service environment. According to domestic actual usage for filter replacement.

## INSTALLATION INSTRUCTIONS

### 7.1 The following installation must be completed by professionals:

1. Open gift box and check whether product and spare parts are completed or not.
2. Install the machine on the right position:
  - a. Disassemble the parts bag, take out integrated valve with 1/4" PT taper pipe, teflon tape, PE pipe, etc.
  - b. Close the cold water Angle valve, using tools unscrewing the weaving hose which connected to the Angle valve, clean the Angle valve threaded to tie ribbons clockwise, and integrated valve with 1/4" PT taper pipe is bound in thread ribbons (5 to 10) at the same time. Using a wrench to connect cold water Angle valve and integrated valve with 1/4" PT taper pipe, then connect braided hose with integrated valve with 1/4" PT taper pipe, (connection integrated valve with 1/4" PT taper pipe, braided hose. Please do not forget to pack rubber mat, in case of leakage), in (figure 1).
  - c. Then connect PE pipe to the integrated valve with 1/4" PT taper pipe with the method (in Figure 2). Finally insert the other end of the PE pipe into the water inlet of this machine, and block with blue card to avoid leakage.

## INSTALLATION INSTRUCTIONS

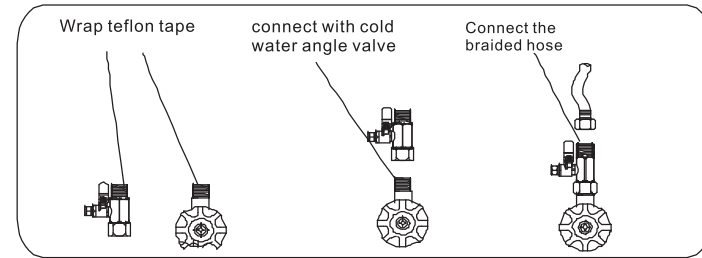

(figure 1)

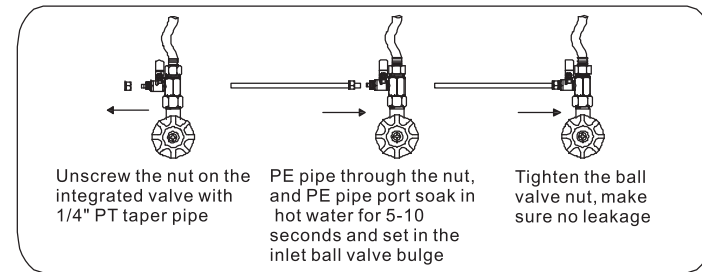

(figure 2)

## INSTALLATION INSTRUCTIONS

### 7.2. The installation diagram

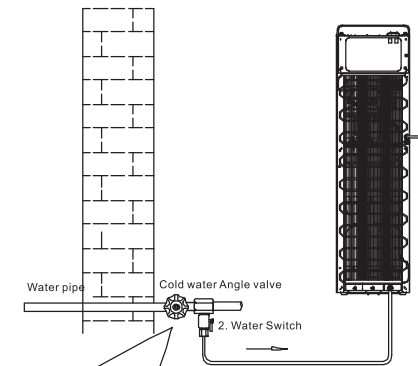

#### Attention

- 1) Cut the pipe, the pipe should be flush.
- 2) Connect the fast connection, must be inserted to the bottom, and with fixed card buckle, in case of leakage.
- 3) When the water pressure is higher than 0.4 Mpa, please install the pressure reducing valve.

## OPERATION INSTRUCTION

### 7.3 FEED WATER

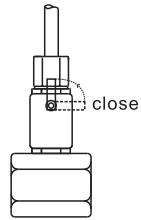

1. Open the 1/4" ball valve, which was connected to water dispenser tube, and check & solve whether the tube is leakage or not.

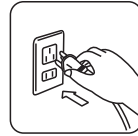

1. Plug in the power

### 7.4 STARTING UP

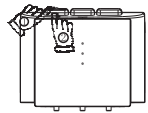

2. Press the hot water safety lock (①), in the meantime, press the hot faucet (②) until get water out.

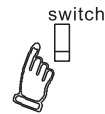

2. Turn on the hot or cold switch as needed

### 7.5 Heating operation:

Turn on the heating switch on the back of the machine. The machine begins to enter the heating function, and the heating lamp is lit. When the hot water temperature reaches the set value, the machine stops heating and enters the heat insulation state.

### 7.6 Cooling operation:

Turn on the cooling switch on the back of the machine, The machine starts to enter the cooling function, refrigeration and so on. When the cold water temperature reaches the set value, the machine stops cooling and enters the heat preservation state.

## FILTER INSTALLATION POSITION

7.7 Install each filter to right position (refer to Fig 5)

- \* 1. PP
- \* 2. CTO
- \* 3. UF
- \* 4. CTO

Notes: When replacing new filter, please make filter in the correct position as above

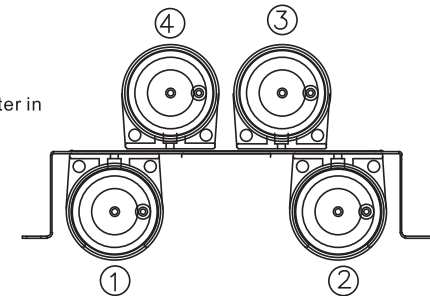

## FILTER INSTALLATION UNINSTALLATION INSTRUCTION

### 7.8 Filter removal and installation:

#### Filter removal:

When the filter life span expires, the filter element needs to be replaced. Replacement of the filter element, to ensure that the water is closed, and the water outlet of the water tap water pressure release 500ml, according to the demolition method shows the first filter, as shown in figure four remove the card, and then remove the filter connector shown in figure five. Remove the filter cartridge as shown in arrow direction six

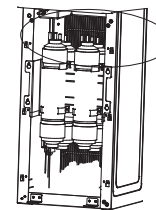

Pic 4: fix the filter element in the direction of the arrow

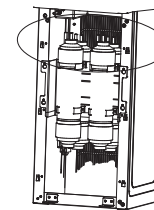

Pic 5: in the direction of the arrow out of the filter joint

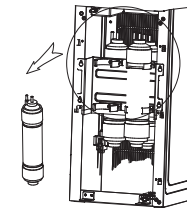

Pic 6: in the direction of the arrow out of the filter

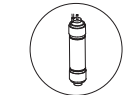

## 7.9 Remove and install the filter:

Filter installation alignment filter element support, according to the seven methods shown in figure eight, installation of the filter connector, and then install the filter blue in figure nine, after installation, and open source switch, the interface to check whether the water leakage.

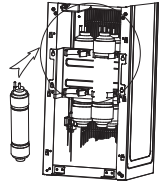

Pic 7: fix the filter element in the direction of the arrow

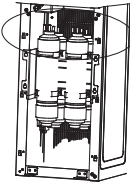
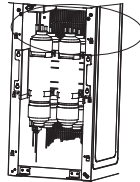

Pic 9: in the direction of the arrow out of the blue card



## Filter element flushing step

### 8.0 Filter rinsing



1. Take out the filter from the unit

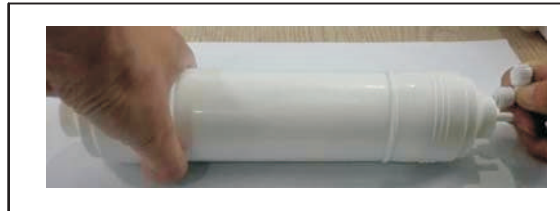

2. Take out quick connector from accessory, connect it to the inlet of filter on the top



3. Connect 1/4 PE pipe of main water (refer to section 7.3) to another side of this quick connector



4. Make filter outlet toward the basin, open the integrated valve to rinse filter. Rinsing must be more than 1 minutes.

**Caution:** Please flush filters until filtered water clean while first use or reusing the product after disuse for a long time.

## FAULT TREATMENT

Non-professional workers do not dismantle the machine, dismantle the machine must be cut off the water supply, power supply.

Fault phenomenon	Fault cause	Fault treatment
<b>Lights do not lit</b>	<ol style="list-style-type: none"> <li>1. Appliance is not connected to the electrical system</li> <li>2. The switch is not ON</li> </ol>	<ol style="list-style-type: none"> <li>1. Make sure that the switch is ON and the plug is connected</li> <li>2. Turn the switch into ON or turn the timer</li> </ol>
<b>Not heating</b>	<ol style="list-style-type: none"> <li>1. Heating switch is damaged or does not make contact</li> <li>2. The heating tank is burnt</li> <li>3. The electrical connection is loose</li> </ol>	<ol style="list-style-type: none"> <li>1. Replace the switch and check the connections</li> <li>2. Replace heating tank</li> <li>3. Repair connections</li> </ol>
<b>Not cooling</b>	<ol style="list-style-type: none"> <li>1. Cooling switch is damaged or does not make contact</li> <li>2. The electrical connection is loose</li> </ol>	<ol style="list-style-type: none"> <li>1. Replace the switch and check the connections</li> <li>2. Repair connections</li> </ol>
<b>No water</b>	<ol style="list-style-type: none"> <li>1. The filter has to change, internal blockage</li> <li>2. The pipe bent</li> </ol>	<ol style="list-style-type: none"> <li>1. Install the blotting paper</li> <li>2. Replaced the filter</li> <li>3. Reinstall the bent pipe</li> </ol>
<b>Leakage or spill water</b>	<ol style="list-style-type: none"> <li>1. Silicone tube not tighten or fall off</li> <li>2. The tap damaged</li> <li>3. Filter or seal not installed in place</li> <li>4. The seal ring deformation</li> <li>5. The water container is broken</li> <li>6. The water pipe is broken</li> </ol>	<ol style="list-style-type: none"> <li>1. Tighten the silicone tube</li> <li>2. Change the faucet</li> <li>3. Reinstall the filter or seal</li> <li>4. Replace the sealing ring</li> <li>5. Replace the water container</li> <li>6. Replace the water pipe</li> </ol>



## ATTENTION

1. Make sure to have poured water from the hot water faucet before plugging and switching the appliance ON to heat. If the dispenser is turned ON with an empty water tank, it can be damaged.
  2. When you are ready to move the water cooler, do not tilt more than 45° to avoid damage to the compressor.
  3. Always install the dispenser indoors, on a flat surface and at a distance no less than 15 cm from the back wall.
  4. Keep this appliance away from high temperatures and in a dry and ventilated place. Never install it in the open air or under rain or direct sunlight.
  5. Children should not use the red hot water tap.
  6. If the appliance is not going to be used for a long period of time, unplug it and drain all water in its interior.
  7. Before the first use and after a long period of not using it, the water tank and water pipes should be cleaned well. If possible, they should be disinfected and disinfect, and the first heated water must be discarded (switch the heating switch to OFF while draining the system).
  8. Wash and disinfect the system every 3-6 months with a suitable cleaner and according to its instructions for use.
  9. Do not pull out the cable to unplug. Do not turn ON and OFF the appliance by connecting it and disconnecting it from the source of electricity.
  10. Do not clean the outside of the appliance with water to avoid electric shock. Clean it with a soft cloth.
  11. If you are not using the appliance for a long period of time or during the night, you can turn it OFF to save energy.
  12. Do not attempt to change the power cord by yourself if it has any damage. Contact the manufacturer or specialized service personnel.
  13. If the power cable suffers any damage, contact the manufacturer, his service representative or qualified personnel.
  14. The equipment must be installed keeping easy access to the electrical plug.
  15. **WARNING** - to avoid the risks of an unstable installation, the equipment must be installed following its instructions.
  16. **WARNING** - keep the ventilation openings at the back of the appliance uncovered and unobstructed.
  17. **NOTICE** - do not damage the refrigerant circuit.
  18. The environmental temperature for this appliance should be between 18° C and 38 ° C.
  19. This appliance can be used by children aged from 8 years and above and persons with reduced physical, sensory or mental capabilities or lack of experience and knowledge if they have been given supervision or instruction concerning use of the appliance in a safe way and understand the hazards involved. Children shall not play with the appliance. Cleaning and use maintenance shall not be made by children without supervision.
- Do not store explosive substances such as aerosol cans with a flammable propellant in this appliance.

## ATTENTION

- This appliance is intended to be used in household and similar applications such as
- staff kitchen areas in shops, offices and other working environments;
  - farm houses and by clients in hotels, motels and other residential type environments;
  - bed and breakfast type environments;
  - catering and similar non-retail applications
20. Do not place other appliances inside this equipment unless those are recommended by the manufacturer.
  21. Do not store explosive substances such as spray cans inside this appliance.

## SPARE PARTS LIST

NO.	Name	Picture	QTY	Remark
1	Integrated valve with 1/4" PT taper pipe		1	
2	1/4 PE pipe		1	
3	PTFE tape		1	

## WARRANTY

### 30-Day Money-Back Guarantee and a limited-year-warranty

We stand proudly by our products and take pride in our customer service. We warrant that our products will be free from defects in all materials and workmanship (excluding paint and finish) for the Warranty Coverage Period described below. This warranty is extended only to the original consumer purchaser. During the Warranty Coverage Period, we will (at our sole option) replace any defective part or product covered by this warranty when provided with proof of purchase. The replacement will be without charge.

#### Coverage Details:

Warranty does not cover normal wear of parts or damage caused by misuse, abuse, overheating and alteration. No alterations are covered in this warranty. AQUART is not responsible for any loss due to neglectful operation. Furthermore, this warranty does not cover products damaged or rendered defective due to accident, misuse, abuse, modification, water damage, neglect, improper handling or storage, improper maintenance or installation, incorporation of third-party components or exposure to weather, natural disasters such as earthquakes, hurricanes, tornadoes, floods, lightning, fires, or failure to follow instructions for use.

ANY WARRANTIES IMPLIED BY LAW SHALL IN NO EVENT EXTEND BEYOND DURATION OF THIS EXPRESS WARRANTY. Some States do not allow limitations on how long an implied warranty lasts, so the above limitation may not apply to you. REPAIR OR REPLACEMENT AS PROVIDED HEREIN IS YOUR EXCLUSIVE REMEDY FOR ANY DEFECTIVE PRODUCT. IN NO EVENT SHALL WE BE LIABLE FOR ANY SPECIAL, INCIDENTAL OR CONSEQUENTIAL DAMAGES OF ANY KIND ARISING OUT OF THE PURCHASE OR USE OF THIS PRODUCT, WHETHER BASED UPON CONTRACT, TORT, STATUTE OR OTHERWISE. Some states do not allow the exclusion or limitation of incidental or consequential damages, so the above limitation or exclusion may not apply to you. This warranty gives you specific legal rights, and you may also have other rights which vary from State to State.

Please keep all original sales receipts from the authorized dealer. Proof of purchase is required to obtain warranty services. Our warranty is limited to all purchases made from VECYS. If you purchased through a different retailer, please contact them directly. (Unauthorized reselling of VECYS products is prohibited.) Any parts or products returned without written authorization will be discarded without notice. To obtain warranty services submit a warranty request by mailing support@aquart.cn. We are happy to help and are available Monday-Sunday, between 9 am to 5 pm PST.

Warranty applies to the United States and Canada.

### Exceptions

There is no written or implied performance warranty on AQUART products, as the manufacturer has no control over the installation, operation, cleaning or the maintenance. This warranty will not apply nor will AQUART assume responsibility if your appliance has not been installed, operated, cleaned, and maintained in strict accordance with the owner's manual. This warranty does not cover damage or breakage due to misuse, improper handling or modifications.

Neither AQUART, or authorized AQUART dealer, accepts responsibility, legal or otherwise, for the incidental or consequential damage to the property or persons resulting from the use of this product. Whether a claim is made against AQUART based on the breach of this warranty or any other type of warranty expressed or implied by law, the manufacturer shall in no event be liable for any special, indirect, consequential, or other damages of any nature whatsoever in excess of the original purchase of this product. All warranties by AQUART are set forth herein and no claim shall be made against AQUART on any warranty or representation. For more information regarding specific terms of warranty coverage, email support@aquart.cn.

## CONTACT CUSTOMER SERVICE

We strongly encourage you to contact us through the platform where you purchased the product. This facilitates faster communication and ensures a smoother after-sales process.

If you've misplaced the paper version of the manual, you can download the electronic version here: [www.aquartonline.com/pages/manual](http://www.aquartonline.com/pages/manual)

